



**AVERY
DENNISON**

Fastener
Solutions

15" Super Bar-Lok[®] Cable Ties Marketing Specifications

For the following part numbers:

10006-0

10008-0

10344-0

10345-0

August 1, 2018

AVERY DENNISON MARKETING SPECIFICATION

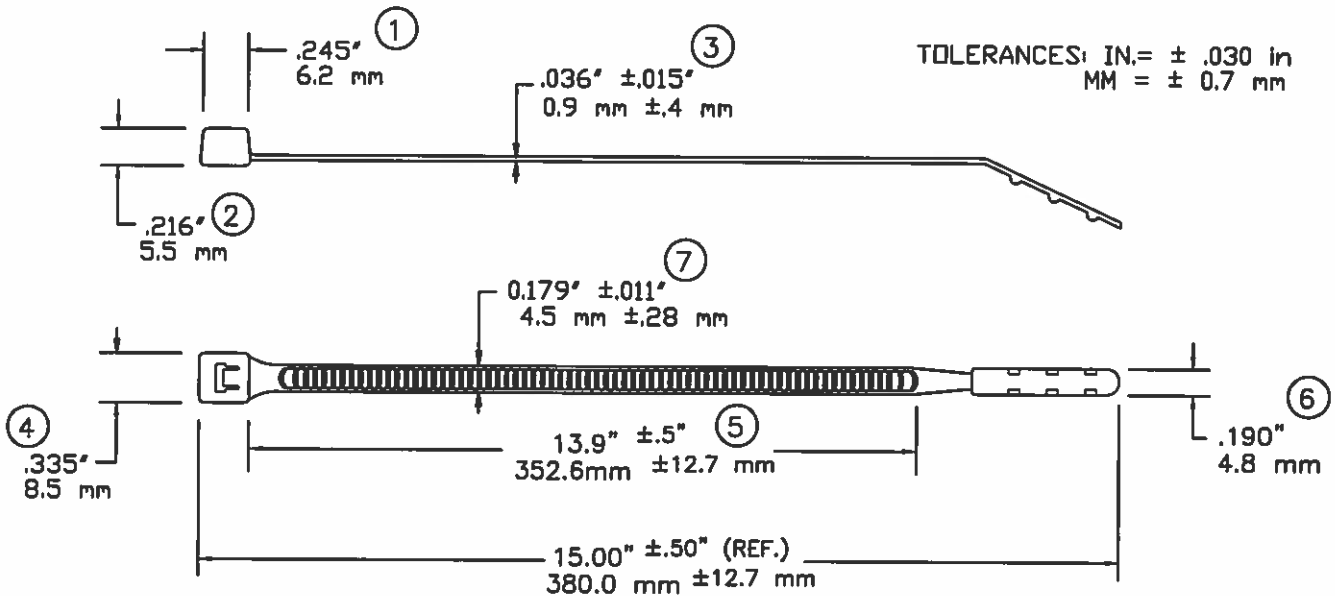

NOT TO SCALE

| | |
|--------------------------|--|
| LOOPED TENSILE STRENGTH: | 50 LBSF. / 220N MINIMUM |
| MILITARY STANDARD: | MS3367-2-9 |
| MATERIAL: | NYLON 6/6 NATURAL |
| WEIGHT: | .0497 oz. / 1.46 grams |
| BUNDLE DIAMETER: | ∅0.063"/1.59mm to ∅4.0"/101.6mm |
| MIN. INSTALLATION TEMP: | 32°F (0°C) |
| OPERATING TEMPERATURE: | -40°F(-40°C) TO 185°F(85°C) |
| APPLICATION TOOL: | TOOL, HAND ADJUSTABLE, FOR PLASTIC TIE DOWN STRAP. AVERY DENNISON PART NUMBER 12001. |
| TOOL TENSION SETTING: | 6-8 |
| PACKAGED IN: | 100/BAG, 1000/CASE |



FASTENER DIVISION
FITCHBURG, MA 01420 U.S.A.
TEL. 1-800-225-5913
MA. 978-353-8157

THESE CABLE TIES ARE PLENUM RATED AND HAS A FLAMMABILITY RATING OF V2



DESCRIPTION:

**15" SUPER BAR-LOK[®] CABLE TIE
STANDARD**

APPROVAL:

Linda Boyd 8/26/15

STOCK NO.

10006-0

REV

N

AVERY DENNISON MARKETING SPECIFICATION

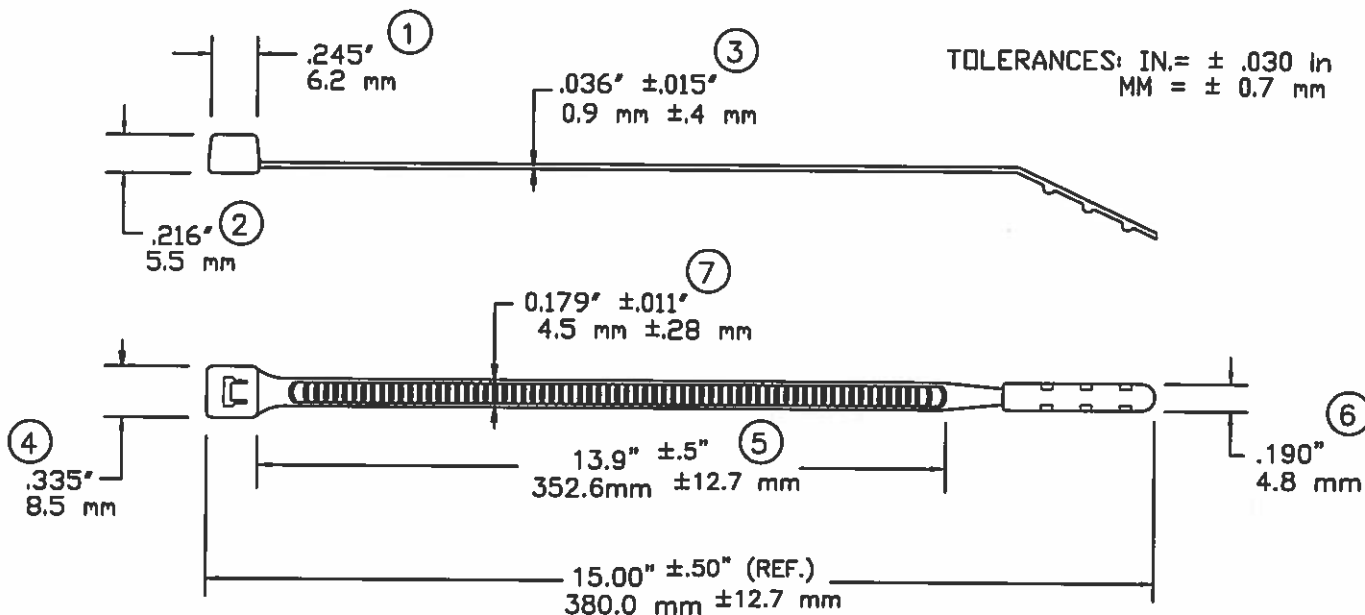

NOT TO SCALE

| | |
|--------------------------|--|
| LOOPED TENSILE STRENGTH: | 50 LBSF. / 220N MINIMUM |
| MILITARY STANDARD: | MS3367-2-0 |
| MATERIAL: | NYLON 6/6 BLACK HEAT STABILIZED |
| WEIGHT: | .0497 oz. / 1.46 grams |
| BUNDLE DIAMETER: | Ø0.063"/1.59mm to Ø4.0"/101.6mm |
| MIN. INSTALLATION TEMP: | 32°F (0°C) |
| OPERATING TEMPERATURE: | -40°F(-40°C) TO 220°F(105°C) |
| APPLICATION TOOL: | TOOL, HAND ADJUSTABLE, FOR PLASTIC TIE DOWN STRAP. AVERY DENNISON PART NUMBER 12001. |
| TOOL TENSION SETTING: | 6-8 |
| PACKAGED IN: | 100/BAG, 1000/CASE |



FASTENER DIVISION
FITCHBURG, MA 01420 U.S.A.
TEL. 1-800-225-5913
MA. 978-353-8157

THESE CABLE TIES ARE PLENUM RATED AND HAS A FLAMMABILITY RATING OF V2



DESCRIPTION:

15" SUPER BAR-LOK[®] CABLE TIE
STANDARD

APPROVAL:

Linda Boyle 8/26/15

STOCK NO.

10008-0

REV

N

EVERY DENNISON MARKETING SPECIFICATION

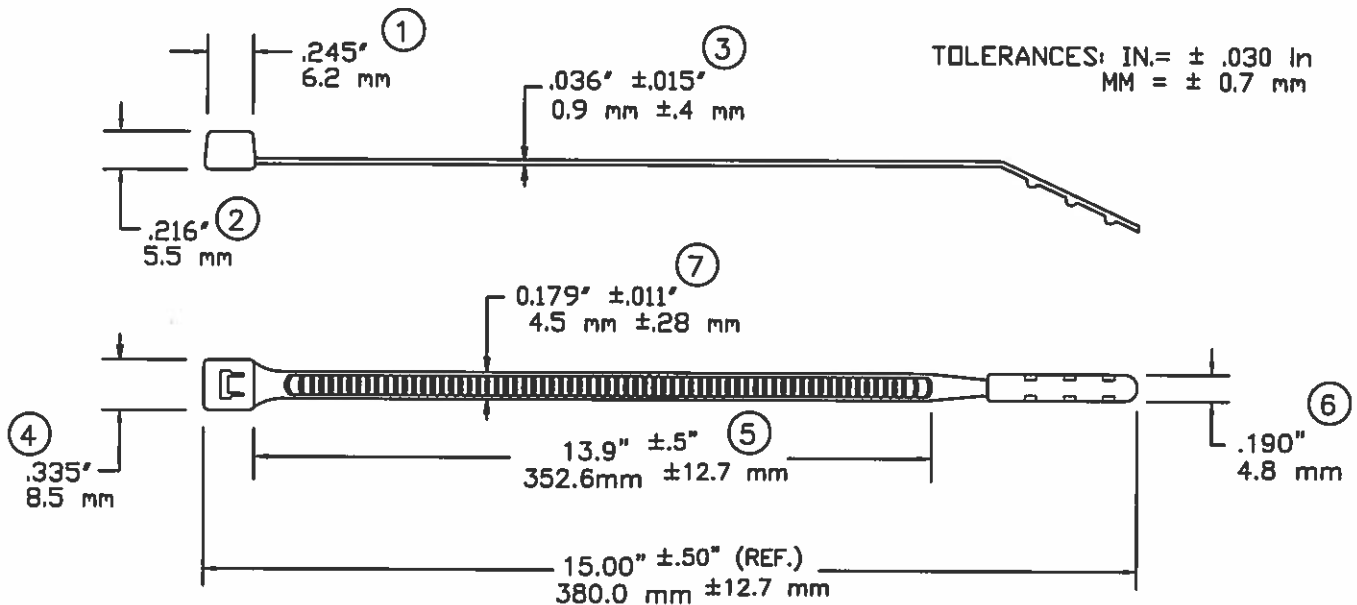

NOT TO SCALE

| | |
|--------------------------|--|
| LOOPED TENSILE STRENGTH: | 50 LBSF. / 220 N MINIMUM |
| MILITARY STANDARD: | MS3367-2-9 |
| MATERIAL: | NYLON 6/6 NATURAL |
| WEIGHT: | .0497 oz. / 1.46 grams |
| BUNDLE DIAMETER: | *0.063"/1.59mm to *4.0"/101.6mm |
| MIN. INSTALLATION TEMP: | 32°F (0°C) |
| OPERATING TEMPERATURE: | -40°F(-40°C) TO 185°F(85°C) |
| APPLICATION TOOL: | TOOL, HAND ADJUSTABLE, FOR PLASTIC TIE DOWN STRAP, AVERY DENNISON PART NUMBER 12001. |
| TOOL TENSION SETTING: | 6-8 |
| PACKAGED IN: | 500/BAG, 5000/CASE |



FASTENER DIVISION
FITCHBURG, MA 01420 U.S.A.
TEL 1-800-225-5913
MA. 978-353-8157

THESE CABLE TIES ARE PLENUM RATED AND HAS A FLAMMABILITY RATING OF V2



DESCRIPTION:

15" SUPER BAR-LOK® CABLE TIE
STANDARD

APPROVAL:

Yvonne Boyle 8/26/15

STOCK NO.

10344-0

REV

E

AVERY DENNISON MARKETING SPECIFICATION

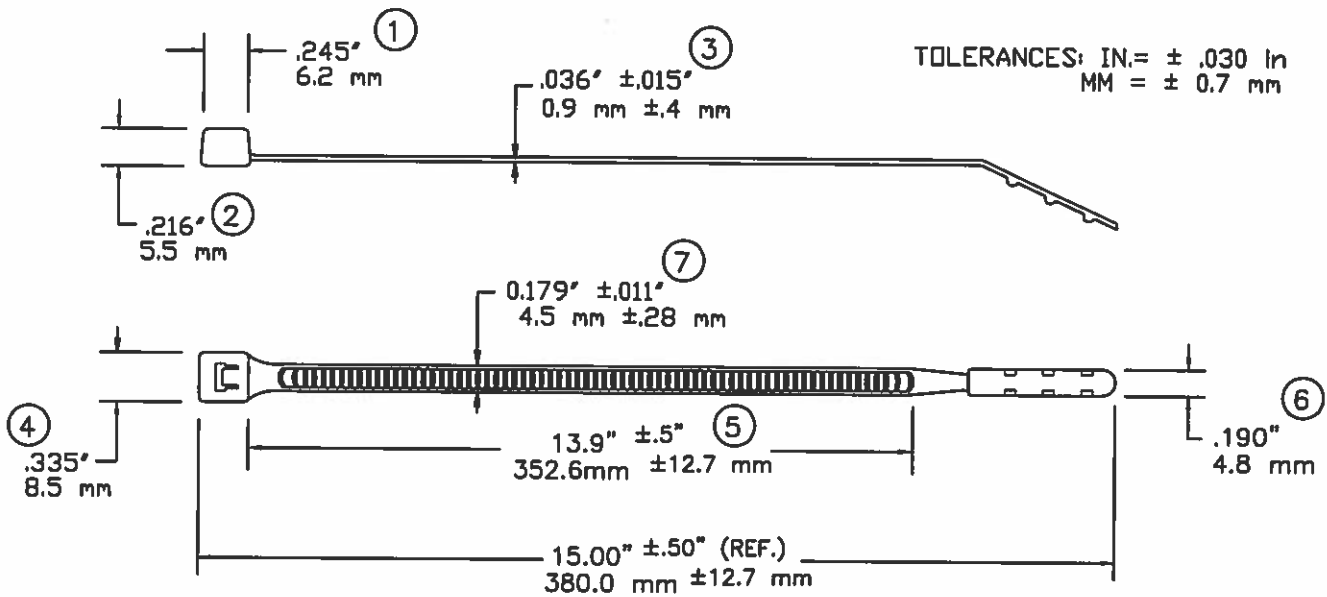

NOT TO SCALE

| | |
|--------------------------|--|
| LOOPED TENSILE STRENGTH: | 50 LBSF. / 220 N MINIMUM |
| MILITARY STANDARD: | MS3367-2-0 |
| MATERIAL: | NYLON 6/6 BLACK HEAT STABILIZED |
| WEIGHT: | .0497 oz. / 1.46 grams |
| BUNDLE DIAMETER: | *0.063"/1.59mm to *4.0"/101.6mm |
| MIN. INSTALLATION TEMP: | 32°F (0°C) |
| OPERATING TEMPERATURE: | -40°F(-40°C) TO 220°F(105°C) |
| APPLICATION TOOL: | TOOL, HAND ADJUSTABLE, FOR PLASTIC TIE DOWN STRAP. AVERY DENNISON PART NUMBER 12001. |
| TOOL TENSION SETTING: | 6-8 |
| PACKAGED IN: | 500/BAG, 5000/CASE |



FASTENER DIVISION
FITCHBURG, MA 01420 U.S.A.
TEL 1-800-225-5913
MA 978-353-8157

THESE CABLE TIES ARE PLENUM RATED AND HAS A FLAMMABILITY RATING OF V2



DESCRIPTION:

15" SUPER BAR-LOK® CABLE TIE
STANDARD

APPROVAL:

Linda Boyle 8/26/15

STOCK NO.

10345-0

REV

G